

# Drain Cleaning Machine



## **⚠ WARNING!**

Read this Operator's Manual carefully before using this tool. Failure to understand and follow the contents of this manual may result in electrical shock, fire and/or serious personal injury.

## Table of Contents

<b>Recording Form for Machine Model and Serial Number</b> .....	1
<b>General Safety Information</b>	
Work Area Safety .....	2
Electrical Safety.....	2
Personal Safety .....	2
Tool Use and Care .....	3
Service .....	3
<b>Specific Safety Information</b>	
Drain Cleaner Safety .....	3
Battery/Charger Safety.....	3
<b>Description, Specifications and Standard Equipment</b>	
Description .....	4
K-39 Specifications/Standard Equipment.....	5
K-39B Specifications/Standard Equipment .....	5
K-39 Optional Equipment .....	5
<b>Drain Cleaner Inspection</b> .....	5
<b>Drain Cleaner and Work Area Set Up</b>	
K-39 Drain Cleaner.....	6
Sink Clog Setup.....	6
Bathtub Clog Setup .....	6
Urinal Clog Setup .....	7
K-39 Battery Charger Setup .....	7
Important Charging Notes .....	7
K-39 Battery Drain Cleaner .....	8
<b>Operation Instructions</b>	
Controls K-39/K-39B .....	8
Cleaning Drain Line Using K-39/K-39B Without Autofeed .....	8
Cleaning Drain Line Using Autofeed .....	9
<b>Special Procedures</b>	
Reverse Operation .....	10
Loading Cable Into Cable Canister .....	10
Loading Cable Without Changing Inner-Drum .....	10
<b>Maintenance Instructions</b>	
Drain Cleaner .....	11
Autofeed .....	11
Lubrication.....	12
Batteries .....	12
<b>Battery Disposal</b>	
Nickel-cadmium Batteries.....	12
Nickel-metal Hydride Batteries .....	12
<b>Accessories</b> .....	13
<b>Machine Storage</b> .....	13
<b>Service and Repair</b> .....	13
<b>Lifetime Warranty</b> .....	Back Cover

# K-39/K-39B

## K-39 and K-39B Cordless Drain Cleaner



**RIDGID**<sup>®</sup>

### K-39/K-39B Drain Cleaner

Record Serial Number below and retain product serial number which is located on nameplate.

Serial  
No.

--	--

## General Safety Information

**WARNING!** Read and understand all instructions. Failure to follow all instructions listed below may result in electric shock, fire, and/or serious personal injury.

### SAVE THESE INSTRUCTIONS!

### Work Area Safety

- **Keep your work area clean and well lit.** Cluttered benches and dark areas invite accidents.
- **Do not operate power tools in explosive atmospheres, such as in the presence of flammable liquids, gases, or dust.** Power Tools create sparks which may ignite the dust or fumes.
- **Keep bystanders, children, and visitors away while operating a power tool.** Distractions can cause you to lose control.

### Electrical Safety

- **Double insulated tools are equipped with a polarized plug (one blade is wider than the other). This plug will fit in a polarized outlet only one way.** If the plug does not fit fully in the outlet, reverse the plug. If it still does not fit, contact a qualified electrician to install a polarized outlet. Do not change the plug in any way. Double insulation  eliminates the need for the three wire grounded power cord and grounded supply system.
- **Avoid body contact with grounded surfaces such as pipes, radiators, ranges and refrigerators.** There is an increased risk of electrical shock if your body is earthed or grounded.
- **Do not expose power tools to rain or wet conditions.** Water entering a power tool will increase the risk of electrical shock.
- **Do not abuse cord. Never use the cord for carrying, pulling or unplugging the power tool. Keep cord away from heat, oil, sharp edges or moving parts.** Damaged or entangled cords increase the risk of electrical shock.
- **When operating a power tool outdoors, use an extension cord suitable for outdoor use.** Use of a cord suitable for outdoor use reduces the risk of electric shock.
- **Use proper extension cords. (See Chart)** Insufficient conductor size will cause excessive voltage drop and loss of power.

Minimum Wire Gauge for Extension Cord			
Nameplate Amps	Total Length (in feet)		
	0 – 25	26 – 50	51 – 100
0 – 6	18 AWG	16 AWG	16 AWG
6 – 10	18 AWG	16 AWG	14 AWG
10 – 12	16 AWG	16 AWG	14 AWG
12 – 16	14 AWG	12 AWG	NOT RECOMMENDED

- **Before using, test the Appliance Leakage Current Interrupter (ALCI) provided with the power cord to insure it is operating correctly.** ALCI reduces the risk of electrical shock.
- **Extension cords are not recommended unless they are plugged into a Ground Fault Circuit Interrupter (GFCI) found in circuit boxes or outlet receptacles.** The ALCI on the machine power cord will not prevent electrical shock from the extension cords.
- **Keep all electric connections dry and off the ground. Do not touch plugs or tool with wet hands.** Reduces the risk of electrical shock.

### Personal Safety

- **Stay alert, watch what you are doing and use common sense when operating a power tool. Do not use a power tool while you are tired or under the influence of drugs, alcohol or medications.** A moment of inattention while operating power tools may result in serious personal injury.
- **Use safety equipment. Always wear eye protection.** Safety equipment such as dust mask, non-skid safety shoes, hard hat, or hearing protection used for appropriate conditions will reduce personal injuries.
- **Avoid accidental starting. Ensure the switch is in the OFF position before plugging in.** Carrying power tools with your finger on the switch or plugging in power tools in that have the switch ON invites accidents.
- **Remove adjusting keys or wrenches before turning the power tool ON.** A wrench or a key left attached to a rotating part of the power tool may result in personal injury.
- **Do not over-reach. Keep proper footing and balance at all times.** This enables better control of the power tool in unexpected situations.
- **Dress properly. Do not wear loose clothing or jewelry. Keep your hair, clothing, and gloves away from moving parts.** Loose clothes, jewelry, or long hair can be caught in moving parts.
- **If devices are provided for the connection of dust**

extraction and collection facilities, ensure these are connected and properly used. Use of these devices can reduce dust-related hazards.

### Power Tool Use and Care

- **Do not force the power tool. Use the correct power tool for your application.** The correct power tool will do the job better and safer at the rate for which it is designed.
- **Do not use the power tool if switch does not turn it ON and OFF.** Any power tool that cannot be controlled with the switch is dangerous and must be repaired.
- **Disconnect the plug from the power source and/or the battery pack from the power tool before making any adjustments, changing accessories, or storing power tools.** Such preventive safety measures reduce the risk of starting the power tool accidentally.
- **Store idle power tools out of the reach of children and do not allow persons unfamiliar with the power tool or these instructions to operate the power tool.** Power tools are dangerous in the hands of untrained users.
- **Maintain power tools. Check for misalignment or binding of moving parts, breakage of parts, and any other condition that may affect the power tool's operation. If damaged, have the power tool repaired before use.** Many accidents are caused by poorly maintained power tools.
- **Keep cutting tools sharp and clean.** Properly maintained cutting tools with sharp cutting edges are less likely to bind and are easier to control.
- **Use the power tool, accessories and tool bits etc. in accordance with these instructions and in the manner intended for the particular type of power tool, taking into account the working conditions and the work to be performed.** Use of the power tool for operations different from those intended could result in a hazardous situation.
- **Keep handles dry and clean; free from oil and grease.** Allows for better control of the tool.

### Service

- **Have your power tool serviced by a qualified repair person using only identical replacement parts.** This will ensure that the safety of the power tool is maintained.

## Specific Safety Information

### **▲ WARNING**

**Read this operator's manual carefully before using the K-39/K-39B Drain Cleaner. Failure to understand and follow the contents of this manual may result in electrical shock, fire and/or serious personal injury.**

Call the Ridge Tool Company, Technical Service Department at (800) 519-3456 if you have any questions.

### Drain Cleaner Safety

- **Never grasp a rotating cable with a rag or loose fitting cloth glove.** It could become wrapped around the cable and cause serious injury.
- **Do not overstress cables.** Overstressing cables may cause twisting or kinking and result in serious injury.
- **Position K-39/K-39B within one foot of inlet.** Greater distances can result in cable twisting or kinking.
- **Do not use tool if switch is broken.** Any tool that cannot be controlled by the switch is dangerous and must be repaired.
- **Machine is designed for one person operation.** Operator must control switch and cable.
- **Do not operate machine in reverse (REV).** Operating machine in reverse can result on cable damage and is only used to back tool out of an obstruction.
- **Do not place this tool in water.** Water entering the motor housing will increase the risk of electrical shock.
- **Only use the K-39/K-39B to clean lines 3/4" to 2 1/2" in diameter. Follow instructions on proper use of the drain cleaner.** Other uses or modifying this drain cleaner for other applications may increase the risk of injury.
- **Be careful when cleaning drains where cleaning compounds have been used. Avoid direct contact with skin and eyes.** Serious burns can result from some drain cleaning compounds.

### Battery/Charger Safety

**▲ WARNING** Before using battery charger, read all instructions and cautionary markings on (1) battery charger, (2) battery pack, and (3) K-39B.

- **Use only the charger which accompanies your product or a direct replacement. Do not substitute any other charger.** May result in battery damage and/or serious injury.
- **Charge only RIDGID No. BP12 rechargeable batteries.** Other types of batteries may burst causing personal injury and damage.

- **Do not disassemble charger or operate the charger if it had received a sharp blow, been dropped or otherwise damaged in any way. Replace damaged cord or plugs immediately.** Incorrect reassembly or damage may result in electric shock or fire.
- **Do not recharge battery in damp or wet environment. Do not expose charger to rain or snow. If battery case is cracked or otherwise damaged, do not insert into charger.** Battery short or fire may result.
- **Charge battery cartridge in temperatures above +40°F (4°C) and below +105°F (41°C). Store tool and battery pack in locations where temperatures do not go below 40°F (4°C) or will not exceed 120°F (49°C). Allow battery pack to return to room temperature before attempting to charge.** Improper care of batteries may result in battery leakage, electrical shock or burns.
- **Battery leakage may occur under extreme usage or temperature conditions. Avoid contact with skin and eyes.** The battery liquid is caustic and could cause chemical burns to tissues. If liquid comes in contact with skin, wash quickly with soap and water, then with lemon juice or vinegar. If the liquid contacts your eyes, flush them with water for a minimum of 10 minutes and seek medical attention.
- **Place charger on flat non-flammable surfaces and away from flammable materials when re-charging battery pack.** The charger and battery pack heat during charging. Carpeting and other heat insulating surfaces block proper air circulation which may cause overheating of the charger and battery pack. If smoke or melting of the case are observed unplug the charger immediately and do not use the battery pack or charger.
- **When batteries are not in tool or charger, keep them away from metal objects.** For example, to protect terminals from shorting DO NOT place batteries in a tool box or pocket with nails, screws, keys, etc. Fire or injury may result.
- **Do not put batteries into fire or expose to high heat.** They may explode causing serious injury.



Figure 1 – K-39 Drain Cleaner With C-1 Cable

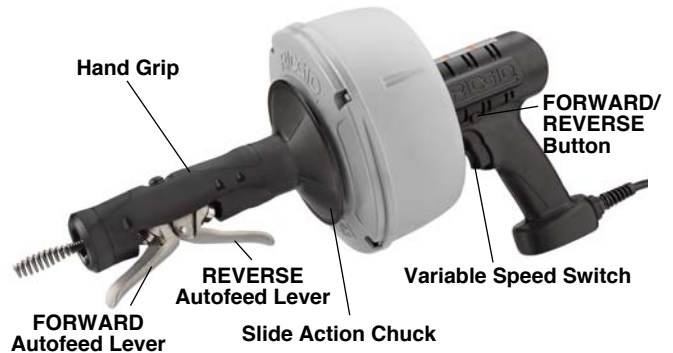

Figure 2 – K-39AF Drain Cleaner

## Description, Specifications and Standard Equipment

### Description

The RIDGID Model K-39 (Figure 1), K-39 AF (Figure 2), and K-39 Battery (Figure 3) are hand-held drain cleaners designed to clean 3/4" to 2 1/2" drain lines in kitchens, bathrooms and utility rooms.

The K-39 electric powered tool is a double-insulated design equipped with polarized plug. Double insulation eliminates the need for the three-wire grounded power cord and grounded supply system. This drain cleaner is available in two styles:

- Slide-Action Chuck
- Slide-Action Chuck with Autofeed Assembly

The slide-action chuck grips the cable so that it can be forced into the blockage as the drum continues to spin.

The autofeed unit automatically feeds and retrieves the cable thereby eliminating the need for manual control.

The Model K-39B (Figure 3) battery powered version eliminates the need for a power outlet or extension cord at the point of application. It is offered with the slide-action chuck and the autofeed assembly.



Figure 3 – K-39B Drain Cleaner

## K-39 Specifications/Standard Equipment

### Power Unit:

Type .....Universal  
 Rating .....115V, single phase, AC,  
 1.1 amp, 60 Hz. (230V available  
 on request)  
 Trigger Switch .....Variable Speed, Reversing

**Operating Speed**.....0-450 RPM

**Drain Line Capacity** ..... $\frac{3}{4}$ " thru 2 $\frac{1}{2}$ "

**Weight w/C1-IC Cable**...10.2 lb

## K-39B Specifications/Standard Equipment

### Power Unit

Type .....Universal  
 Rating .....12V, DC  
 Trigger Switch .....Variable Speed, Reversing

**Operating Speed**.....0-700 RPM

**Drain Line Capacity** ..... $\frac{3}{4}$ " thru 2 $\frac{1}{2}$ "

**Weight w/C-1 Cable** .....9.5 lbs.

## K-39 Optional Equipment

Autofeed .....2 Way Autofeed Mechanism

NOTE! *Table 1* lists 8 combinations of standard equipment that are available with the basic K-39 Drain Cleaner.

Catalog No.	Model No.	Description
68057	K-39	K-39 Drain Cleaner C-11C Cable w/Bulb Auger ( $\frac{5}{16}$ " x 25')
68137	K-39B	K-39B Cordless Drain Cleaner, BP12 Battery Pack, BC12 Charger, C-1 Cable w/Bulb Auger ( $\frac{5}{16}$ " x 25')
68062	K-39-1	Same as Model No. K-39 plus: C-6429 Carrying Case
68142	K-39B-1	Same as Model No. K-39B plus: (1) additional BP12 Battery Pack C-6429 Carrying Case
68067	K-39-5	K-39 Drain Cleaner C-11C Cable w/Bulb Auger ( $\frac{5}{16}$ " x 25') C-6 Cable w/ $\frac{5}{8}$ " Coupling ( $\frac{3}{8}$ " x 35') A-13 Pin Key T-203 Bulb Auger T-205 "C" Cutter T-210 Grease Cutter T-217 Drop Head Auger C-6429 Carrying Case
68072	K-39-7	K-39 Drain Cleaner C-11C Cable w/Bulb Auger ( $\frac{5}{16}$ " x 25') C-6 Cable w/ $\frac{5}{8}$ " Coupling ( $\frac{3}{8}$ " x 35') C-21 Cable w/Bulb Auger ( $\frac{5}{16}$ " x 50') A-13 Pin Key T-203 Bulb Auger T-205 "C" Cutter T-210 Grease Cutter T-217 Drop Head Auger C-6429 Carrying Case
21888	K-39AF	K-39 Drain Cleaner C-11C Cable w/Bulb Auger ( $\frac{5}{16}$ " x 25') Autofeed
23508	K-39AF-1	K-39-1 with Autofeed
23513	K-39AF-5	K-39-5 with Autofeed
23518	K-39AF-7	K-39-7 with Autofeed
23523	K-39B-AF-1	K-39B-1 with Autofeed

Table 1 – Equipment Available with Standard Models

## Drain Cleaner Inspection

### ▲ WARNING



**To prevent serious injury, inspect your Drain Cleaning Machine. The following inspection procedures should be performed before each use.**

1. Make sure the Drain Cleaning Machine is unplugged.
2. Electrical components:

K-39 Drain Cleaner:

Inspect the power cord, Appliance Leakage Current Interrupter (ALCI) and plug for damage. If the plug has

been modified or if the cord is damaged, do not use the Drain Cleaner until the cord has been replaced.

**K-39 Battery Charger:**

Inspect the power cord and plug for damage. If the cord or plug is damaged, do not use the charger until the cord is replaced. Inspect charger for damage. Do not use charger if it has received a sharp blow, been dropped or otherwise damaged.

3. Inspect the Drain Cleaning Machine for any broken, missing, misaligned or binding parts as well as any other conditions which may affect the safe and normal operation of the machine. If any of these conditions are present, do not use the Drain Cleaning Machine until any problem has been repaired.
4. Lubricate the Drain Cleaner and the autofeed unit, if necessary, according to the Maintenance Instructions.
5. Use accessories that are designed for your drain cleaner and meet the needs of your application. The correct accessories allow you to do the job successfully and safely. Accessories suitable for use with other equipment may be hazardous when used with this drain cleaner.
6. Clean any oil, grease or dirt from all equipment handles and controls. This reduces the risk of injury due to a tool or control slipping from your grip.
7. Inspect cables and couplings for wear and damage. Cables should be replaced when they become severely worn or corroded. A worn cable can be identified when the outside coils become flat or having several kinks throughout the cable.

**▲ WARNING** Worn or damaged cables can break causing serious injury.

**Drain Cleaner and Work Area Set-Up**

**▲ WARNING**

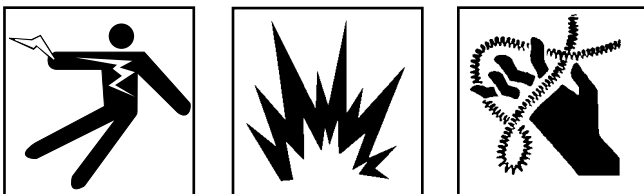

**To prevent serious injury, proper set-up of the drain cleaner and work area is required. The following procedures should be followed to set-up the K-39 and K-39B:**

**K-39 Drain Cleaner:**

1. Check work area for:
  - Adequate lighting.
  - No flammable liquids, vapors or dust that may ignite.
  - Clear path to the electrical outlet that does not contain any sources of heat or oil, sharp edges or moving parts that may damage electrical cord.
  - Dry place for operator.
2. Make sure trigger is not engaged.
3. Plug the Drain Cleaner into the electrical outlet, making sure to position the power cord along the clear path selected earlier. If the power cord does not reach the outlet, use an extension cord in good condition.

**▲ WARNING** To avoid electrical shock and electrical fires, never use an extension cord that is damaged or does not meet the following requirements:

- The cord is rated as “W” or “W-A” if being used outdoors.
- The cord has sufficient wire thickness (16 AWG below 50’/14 AWG 50’ - 100’). If the wire thickness is too small, the cord may overheat, melting the cord’s insulation or causing nearby objects to ignite.

**▲ WARNING** To reduce risk of electrical shock, keep all electrical connections dry and off the ground. Do not touch plug with wet hands. Test the Appliance Leakage Current Interrupter (ALCI) provided with the electrical cord to insure it is operating correctly. When test button is pushed in, the reset button should pop up. If the ALCI does not function correctly, do not use the machine. Press reset button to restore power. Do not place the drain cleaner in water.

**Sink Clog Setup:**

1. First, remove the sink’s P-trap by unscrewing it at both ends. Remember to place a bucket under the sink to catch backed up water. Clean out any debris that may be stuck in the P-trap.
2. Place the K-39 close to the drain pipe that is coming out of the wall and follow the operating instructions.

**Bathtub Clog Setup:**

1. Remove the tub’s overflow cover plate. Pull out all of the stopper linkage in order to expose the open hole.

**CAUTION** DO NOT run the machine through the drain in the bottom of the tub. ALWAYS go through the tub’s overflow.

2. Place the K-39 close to the overflow opening and follow the operating instructions.



## Urinal Clog Setup:

1. Remove urinal from wall. Place a bucket under drain to catch any backed up water. Clean out any debris that may be stuck in urinal.

**CAUTION** Trying to clean drain through urinal may damage porcelain.

2. Follow operating instructions below to clean drain.

## K-39 Battery Charger Setup

### Battery Charging Procedure:

#### **▲ WARNING**

**Before using the battery charger, read all the instructions included with the battery and charger.**

1. Locate the charger so the cord and charger will not be stepped on, tripped over or be subjected to damage. Do not expose charger to wet environment such as rain or snow.
2. Charge battery cartridge in temperatures above 40°F (4°C) and below 105°F (41°C). Store tool and battery cartridge in location where temperatures do not exceed 120°F (49°C) or go below 40°F (4°C). Allow battery pack to return to room temperature before attempting to charge.
3. Plug the battery charger into the proper A/C voltage source.

**▲ WARNING** To avoid electric shock and electrical fires, never use an extension cord that is damaged or does not meet the following requirements:

- The cord has pins on line plug that are similar in size and shape to those of the plug on the charger.
  - The cord is rated as “W” or “W-A” if being used outdoors.
  - The cord has sufficient wire thickness (16 AWG below 100’). If the wire thickness is too small, the cord may overheat, melting the cord’s insulation or causing nearby objects to ignite.
4. Before inserting battery pack, remove protective cap, then insert battery pack into charger.
  5. When battery cartridge is inserted, the charger’s green indicator will begin to “BLINK”. This indicates that the battery is receiving a fast charge. Fast-charging will automatically stop when the battery pack is fully charged.

When the indicator light stops “BLINKING” (and becomes a steady green light) fast charging is complete.

When you begin the charging process of the battery

pack, a steady green light could also mean the battery pack is too hot or too cold.

The purpose of the light is to indicate that the battery pack is fast-charging. It does not indicate the exact point of full charge. The light will stop blinking in less time if the battery pack was not completely discharged.

When the battery pack is fully charged, unplug the charger (unless you’re charging another battery pack) and slip the battery pack back into the tool handle.

To prevent fire or injury when batteries are not in tool or charger, always place protective cap onto end of battery pack.

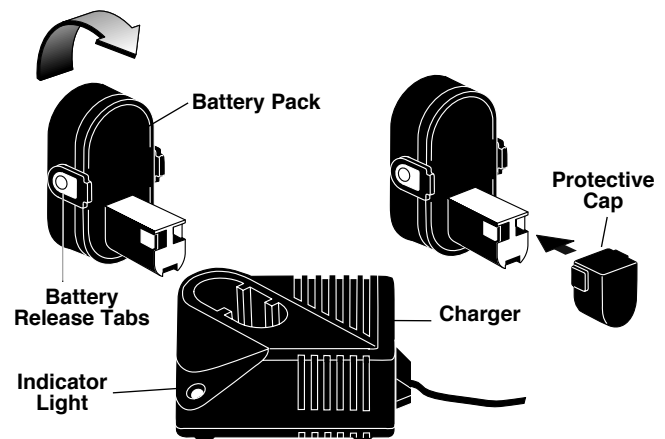

Figure 4 – Charging Battery Pack

NOTE! Charging time will be approximately one hour.

#### **▲ WARNING**

**Charge only RIDGID-type batteries. Other types of batteries may burst causing personal injury.**

5. After charging, unplug the charger from the power source.

### Important Charging Notes

1. The battery pack accepts only about 80% of its maximum capacity with its first few charge cycles. However, after the first few charge cycles, the battery will charge to full capacity.
2. The charger was designed to fast charge the battery only when the battery temperature is between 40°F (4°C) and 105°F (41°C).
3. A substantial drop in operating time per charge may mean that the battery pack is nearing the end of its life and should be replaced.
4. If you anticipate long periods (i.e. a month or more) of non-use of your tool, it is best to run your tool down

until it is fully discharged before storing your battery pack. After a long period of storage, the capacity at first recharge will be lower. Normal capacity will be restored in two or three charge/discharge cycles. Remember to unplug charger during storage period.

5. If battery does not charge properly:
  - A. Check for voltage at outlet by plugging in some other electrical device.
  - B. Check to see if outlet is connected to a light switch which turns power "OFF" when lights are turned off.
  - C. Check battery pack terminals for dirt. Clean with cotton swab and alcohol if necessary.
  - D. If you still do not get proper charging, take or send tool, battery pack and charger to your Ridge Tool Service Center.

### K-39 Battery Drain Cleaner

1. Release battery pack from tool by pressing on both sides of the battery release tabs and pull downward. To insert battery, align battery and slide battery pack into tool until it locks into position. Do not force.
2. Check work area for:
  - Adequate lighting
  - Dry place for operator.
  - Flammable liquids, vapors or dust that may ignite.

## Operating Instructions

▲ **WARNING**

**Never grasp a rotating cable with a rag or loose fitting cloth glove that may become wrapped around the cable causing serious injury.**

**Always wear eye protection to protect your eyes against dirt and other foreign objects. Wear rubber soled, non-slip shoes.**

**Be very careful when cleaning drains where chemical compounds have been used. Avoid direct contact of the skin and especially the eyes and facial area as serious burns can result. Rinse hands thoroughly after contact with chemical compounds.**

### Controls

**CAUTION** Know the location and function of all controls before using this drain cleaner.

### Slide-Action Chuck

Pull hand grip REARWARD and it locks into engaged position to grip cable. This action locks the cable so it can be forced into blockage as the drum continues to spin. This also does not allow the cable to be forced back into the drum when meeting resistance (*Figure 5*). Push hand grip FORWARD to disengage and draw cable out of or into cable canister.

### Variable Speed Switch

Operate at any speed from 0 to maximum 450 RPM, 700 RPM for the cordless version. The speed is controlled by the pressure you apply to the trigger. Apply more pressure to increase speed and release pressure to decrease speed.

### FORWARD/REVERSE Button

The FORWARD/REVERSE Button, located above the variable speed trigger switch, changes rotation of cable. For clockwise rotation (normal), push button to left (FORWARD) position. For counterclockwise rotation, push button to right (REVERSE) position.

**CAUTION** Power unit must be completely stopped before moving FORWARD/REVERSE switch. REVERSE position is used only when removing cable from an obstruction.

**NOTE!** While using the K-39 AF, you do not need to reverse the direction of the power source to retrieve the cable. Simply use the reverse lever on the autofeed. However, if you do get stuck in an obstruction or need to "unscrew" out of something put the unit in reverse.

**CAUTION** Putting an AF unit in reverse will change the rotation of the cable and therefore switch the autofeed direction levers (forward will become reverse and vice versa).

### Cleaning Drain Line Using K-39 and K-39 Battery Without Autofeed

1. Place FORWARD/REVERSE button in FORWARD position.



**Figure 5 – Pull Hand Grip Rearward To Engage Clutch**

2. Push Handgrip FORWARD to disengage clutch. Pull 10 to 12 inches of cable out of canister and insert into line to be cleaned.
3. Pull Handgrip REARWARD until it “snap locks” into the engaged position. (Figure 5) Squeeze Variable Speed Trigger Switch gently and carefully push the cable down the line (Figure 6). Do not force, as cable will tend to kink.
4. Push Handgrip FORWARD to disengaged position. Draw an additional 10 to 12 inches of cable from the canister. (Figure 7)
5. Repeat steps 3 and 4 until you reach the drain blockage.

**NOTE!** Know how long your run of pipe is prior to cleaning. Running too much cable in can damage your equipment and cable.



**Figure 6 – Push Cable Down Drain Line**



**Figure 7 – Pull Handgrip FORWARD To Disengage Clutch and Draw Additional Cable From Canister**

**CAUTION** When you reach the blockage, pull hand grip rearward to engaged position to grip the cable. Work cable back and forth to clear obstruction. At this point, progress depends on the type of tool being used and nature of the blockage. Advance cable slowly.

**▲ WARNING**

**Do not allow tension to build up in the cable. This**

**will happen if the cutting tool hits a snag and stops turning but the motor and cable continue to rotate. Torque builds until the cable suddenly twists, potentially wrapping around your hand or arm. This can happen quickly and without warning, so proceed slowly and carefully as you feed the cable into the drain. If tool gets hung up in an obstruction, refer to Reverse Operating Instructions in the “Special Procedures” section.**

6. Once drain is open and flowing, continue feeding additional cable to clean rest of drain.
7. To withdraw cable from the line, leave FORWARD/REVERSE button in FORWARD position, pull handgrip REARWARD to engaged position and pull back on entire drain cleaner.
8. As excess cable is retracted from the line, push handgrip FORWARD to disengaged position and push cable back into the canister.
9. Continue withdrawing cable by following steps 7 and 8 until cable end emerges.
10. Completely release trigger switch just prior to cable emerging from drain opening. Retrieve by hand as head/tool may contain debris and splash work area.

### **Cleaning Drain Line Using K-39 and K-39 Battery With Autofeed**

1. Insert cable into drain opening by hand as far as possible before turning machine on. Leave approximately 6" of cable between drain opening and nose of machine (Figure 8).



**Figure 8 – Keep Distance Between Drain Opening and Nose of Drain Gun to 6" or Less**

2. Be sure machine FORWARD/REVERSE button is in the FORWARD position.
3. Squeeze trigger and be sure entire cable is spinning before continuing.

**NOTE!** The autofeed cannot be used while the hand grip chucking mechanism is engaged. Be sure the hand grip is pushed forward all the way.

- Depress the forward autofeed lever to feed cable into drain.

NOTE! Know how long your run of pipe is prior to cleaning. Running too much cable can damage your equipment and the cable.

- Feed cable into drain until obstruction is encountered or cable begins to bind up.
- Release the forward autofeed lever and back the cable up using the reverse autofeed lever. Then use the forward lever to again feed the cable to remove the obstruction a piece at a time. Continue this back and forth until you have broken through the obstruction.

**⚠ WARNING**

**Do not allow tension to build up in the cable. This will happen if the cutting tool hits a snag and stops turning but the motor and cable continue to rotate. Torque builds until the cable suddenly twists, potentially wrapping around your hand or arm. This can happen quickly and without warning, so proceed slowly and carefully as you feed the cable into the drain. If tool gets hung up in an obstruction, refer to Reverse Operating Instructions in the “Special Procedures” section.**

- Once drain is open and flowing, continue feeding additional cable with autofeed to clean rest of drain.
- To retrieve cable, simply depress the reverse autofeed lever.

NOTE! There is no need to reverse the motor direction to retrieve the cable. Simply depress the reverse autofeed lever.

- Completely release trigger just prior to cable or tool emerging from drain opening. Retrieve by hand as cable or tool may contain debris and splash work area.

## Special Procedures

### Reverse Operation

If cable/blade gets *hung up* in obstruction, release trigger switch and let motor come to a complete stop before reversing. Place FORWARD/REVERSE button in REVERSE position. Press trigger switch only until cable/blade is free of obstruction. Release trigger switch immediately.

**CAUTION** Only run machine in REVERSE if relieving blade from a blockage.

NOTE! When motor direction is in reverse; autofeed directional levers will be reversed, (FORWARD will become REVERSE and vice versa).

As soon as cable/blade is free and motor has stopped, return FORWARD/REVERSE button to FORWARD position.

## Loading Cable Into Cable Canister

**⚠ WARNING** Make sure machine is unplugged from power source before loading cable.

Your K-39 and K-39B is supplied with an inner drum that fits snugly inside the cable canister that allows easy change-out of cable. Models that include extra cable as standard equipment come with an inner drum for each cable. To utilize the inner drum feature:

- Pull hand grip forward to the disengaged position.
- Loosen the four (4) screws that hold the canister front half to the back half. Loosen each screw 3 (three) full turns (*Figure 9*).
- Separate the canister front half from the back half by twisting apart.
- Lift the inner drum, with cable, out of its cradled fit.
- Fit the new inner drum into the canister’s back half and draw about a foot of cable out of the inner drum (*Figure 10*).



**Figure 9 – Loosen Four (4) Screws From Back Half of Canister About Three (3) Full Turns**

- Pass the exposed cable head through the front half assembly, align the front half with the back half of the canister, and rotate drum front to lock into position. Tighten the screws.
- For AF versions, you will need to pull up on both the FORWARD and REVERSE autofeed levers to fit bulb of cable through autofeed.



Figure 10A – When Loading Cable Into an Inner Drum, Wind the Cable in Clockwise



Figure 10B – Pass Exposed Cable Through Front Half and Reassemble to Back Half of Canister

### Loading Cable Without Changing The Inner Drum

1. Pull hand grip forward to the disengaged position.
2. Insert small end of cable into opening in the front end of the canister's front half and continue feeding entire cable into canister (Figure 11).



Figure 11 – Loading Loose Cable Into Canister

NOTE! For easier cable installation, bend small end of cable one inch from end 15 to 30 degrees. (Refer to Figure 12)



Figure 12 – Bending Cable for Easier Installation

## Maintenance Instructions

### ⚠ WARNING

**Make sure machine is unplugged from power source before performing maintenance or making any adjustment.**

### Drain Cleaner

1. Cables should be thoroughly flushed with water after each use to prevent damaging effects of drain cleaning compounds. Use RIDGID Cable Rust Inhibitor or an equivalent oil.

NOTE! When not in use, store cables indoors to prevent deterioration by the elements.

Cables should be replaced when they become severely corroded or worn. A worn cable can be identified when outside coils of cables become flat.

2. Use a clean cloth to wipe the unit off. Oil, grease and other substances may cause deterioration. Certain cleaning agents and solvents damage plastic parts. Some of these are: gasoline, carbon tetrachloride, chlorinated cleaning solvents, ammonia and household detergents that contain ammonia. Avoiding use of these and other types of cleaning agents minimizes the probability of damage.
3. Regularly drain the inner drums of any captured liquid. Simply hold the machine nose down and drain excess liquid each time the machine is used.
4. Store the unit where it is cool and dry. Avoid those areas where the temperature will drop to 0°F or exceed +120°F.

About once a year, return your K-39 to the nearest RIDGID Authorized Service Center for the following:

- Parts cleaned and inspected.
- Relubricated with fresh lubricant.
- Electrical system tested.
- All repairs.

### Autofeed

A drop of grease to the following areas once a month will extend the life of the autofeed unit and keep it well maintained:

- Pivot arm/spring location.

The autofeed will accumulate dirt, grease and debris over time. Periodically remove the autofeed unit and clean.

To remove autofeed:

1. Remove bolt on hand grip using allen key (*Figure 13A*).



**Figure 13A**

2. Push cable back so that it is past the autofeed.
3. Remove autofeed cartridge. (*Figure 13B*)



**Figure 13B**

**NOTE!** When replacing autofeed cartridge it will only fit in one way.

Once a week a light grease should also be applied to the autofeed roller bearing surface. This will extend the life of the bearings and keep them free to operate properly.

### Lubrication

Disassembly of the K-39/K-39B Drain Cleaner monthly for cleaning and lubrication:

1. Disassemble Manual Unit:
  - a. Remove (2) nose piece screws.
  - b. Remove nose piece.
  - c. Remove external retaining ring using retaining ring pliers.
  - d. Pull off hand grip assembly.

2. Disassemble Autofeed Unit:
  - a. Remove grip top cover by squeezing in and pulling up.
  - b. Remove external retaining ring using retaining ring pliers.
  - c. Pull off hand grip assembly.
  - d. Remove springs. The two clamp springs attach to canister front half in a manner similar to a pegboard hook.
  - e. Remove Autofeed cartridge by removing bottom screw from grip assembly.
3. Thoroughly clean all parts. If required, use emery cloth to remove rust and/or scale from inside of sleeve.
4. Coat springs and inside sleeve with good quality bearing grease and reassemble.

### Batteries

1. Be alert for battery packs that are nearing their end of life. Battery packs typically last from 250 to 500 charges. If you notice decreased tool performance or significantly shorter running time between charges then it is time to replace the battery pack. Failure to do so can cause the tool to operate improperly or damage the charger.
2. Long term battery storage should be in the discharged state. Battery packs last longer and re-charge better when they are stored discharged. Remember to fully re-charge battery packs before using after prolonged storage.

### Battery Disposal

**▲ WARNING** Do not attempt to disassemble the battery or remove any component projecting from the battery terminals. Fire or injury may result. Prior to disposal, protect exposed terminals with heavy insulating tape to prevent shorting.

### Nickel-cadmium Batteries

If equipped with a nickel-cadmium battery, the battery must be collected, recycled or disposed of in an environmentally sound manner.

Please call 1-800-8 BATTERY for information on Ni-Cd battery recycling and disposal bans/restrictions in your area.

### Nickel-metal Hydride Batteries

If equipped with a nickel-metal hydride battery, the battery can be disposed of in a municipal solid waste stream.

## Accessories

Only the following RIDGID products have been designed to function with the K-39/K-39B Drain Cleaners. Other accessories suitable for use with other tools may become hazardous when used on the K-39/K-39B. To prevent serious injury, use only the accessories listed below.

### Cables

Catalog No.	Model No.	Description
62225	C-1	25' (7,62m) w/Bulb Auger
56782	C-11C	5/16" x 25' (7,62m) Inner Core w/Bulb Auger
89400	C-21	50' (15,24m) w/Bulb Auger
56792	C-1311C	35' (10,67m) Inner Core w/Bulb Auger
62235	C-2	25' (7,62m) w/Drop Head Auger
56787	C-21C	25' (7,62m) Inner Core w/Drop Head Auger
89405	C-22	50' (15,24m) w/Drop Head Auger
56797	C-231C	35' (10,67m) w/Drop Head Auger
62245	C-4	25' (7,62m) w/Male Coupling
62250	C-5	35' (10,67m) w/Bulb Auger
62260	C-6	35' (10,67m) w/Male Coupling
96037	C-61C	35' (10,67m) Inner Core w/Male Coupling
50647	S-1	15' with Bulb Auger
50652	S-2	25' with Bulb Auger
50657	S-3	35' with Bulb Auger

### Tools – Fits C-4, C-6 & C-61C Cables

Catalog No.	Model No.	Description
62067	T-201A	Straight Flex Auger
62990	T-201	Straight Auger, 5" Long
62995	T-202	Bulb Auger, 1 1/8" O.D.
63000	T-203	Bulb Auger, 7/8", O.D.
55457	T-225	Retrieving Auger
63065	T-217	Drop Head, 4" Long
54837	T-204	"C" Cutter, 1"
63005	T-205	"C" Cutter, 1 3/8"
63010	T-206	Funnel Auger, 3" Long
63030	T-210	Grease Cutter, 1"
63035	T-211	Grease Cutter, 1 3/8"
63040	T-212	Grease Cutter, 1 3/4"
63045	T-213	4-Blade Cutter, 1"
63050	T-214	4-Blade Cutter, 1 3/8"
63055	T-215	4-Blade Cutter, 1 3/4"
63060	T-216	Chain Knocker, 2"
63280	T-218	Flue Brush, 3"
63070	T-219	Flue Brush, 2 1/2"
63080	T-220	Flue Brush, 2"
63220	T-221	Flue Brush, 1 1/2"
52812	T-230	H-D "C" Cutter, 2"
52817	T-231	H-D "C" Cutter, 2 1/2"
52822	T-232	H-D "C" Cutter, 3"
48482	T-250	Tool Set includes: – T-203 – T-210 – A-13 – T-205 – T-217

## Accessories

Catalog No.	Model No.	Description
18658	BP12	Cordless Battery Pack
17138	BC12	Charger
68917	—	K-38/K-39 Inner-Drum
89410	C-6429	Carrying Case
55242	—	K-39 Chuck Kit
76817	—	C-6 Cable Kit Incl. Inner Drum, C-6 Cable, Torque Arm, T-250 Tool Set
98072	—	C-61C Cable Kit Incl. Inner Drum, C-61C Cable, Torque Arm, T-250 Tool Set

## Machine Storage

Motor-driven equipment must be kept indoors or well covered in rainy weather. Store the tool in a locked area that is out of reach of children and people unfamiliar with drain cleaners. This drain cleaner can cause serious injury in the hands of untrained users.

## Service and Repair

### ▲ WARNING



The "Maintenance Instructions" will take care of most of the service needs of this machine. Any problems not addressed by this section should only be handled by an authorized RIDGID service technician.

Tool should be taken to a RIDGID Independent Authorized Service Center or returned to the factory. All repairs made by Ridge service facilities are warranted against defects in material and workmanship.

**▲ WARNING** When servicing this machine, only identical replacement parts should be used. Failure to follow these instructions may create a risk of electrical shock or other serious injury.

If you have any questions regarding the service or repair of this machine, call or write to:

Ridge Tool Company  
 Technical Service Department  
 400 Clark Street  
 Elyria, Ohio 44035-6001  
 Tel: (800) 519-3456  
 E-mail: TechServices@ridgid.com

For name and address of your nearest Independent Authorized Service Center, contact the Ridge Tool Company at (800) 519-3456 or <http://www.ridgid.com>





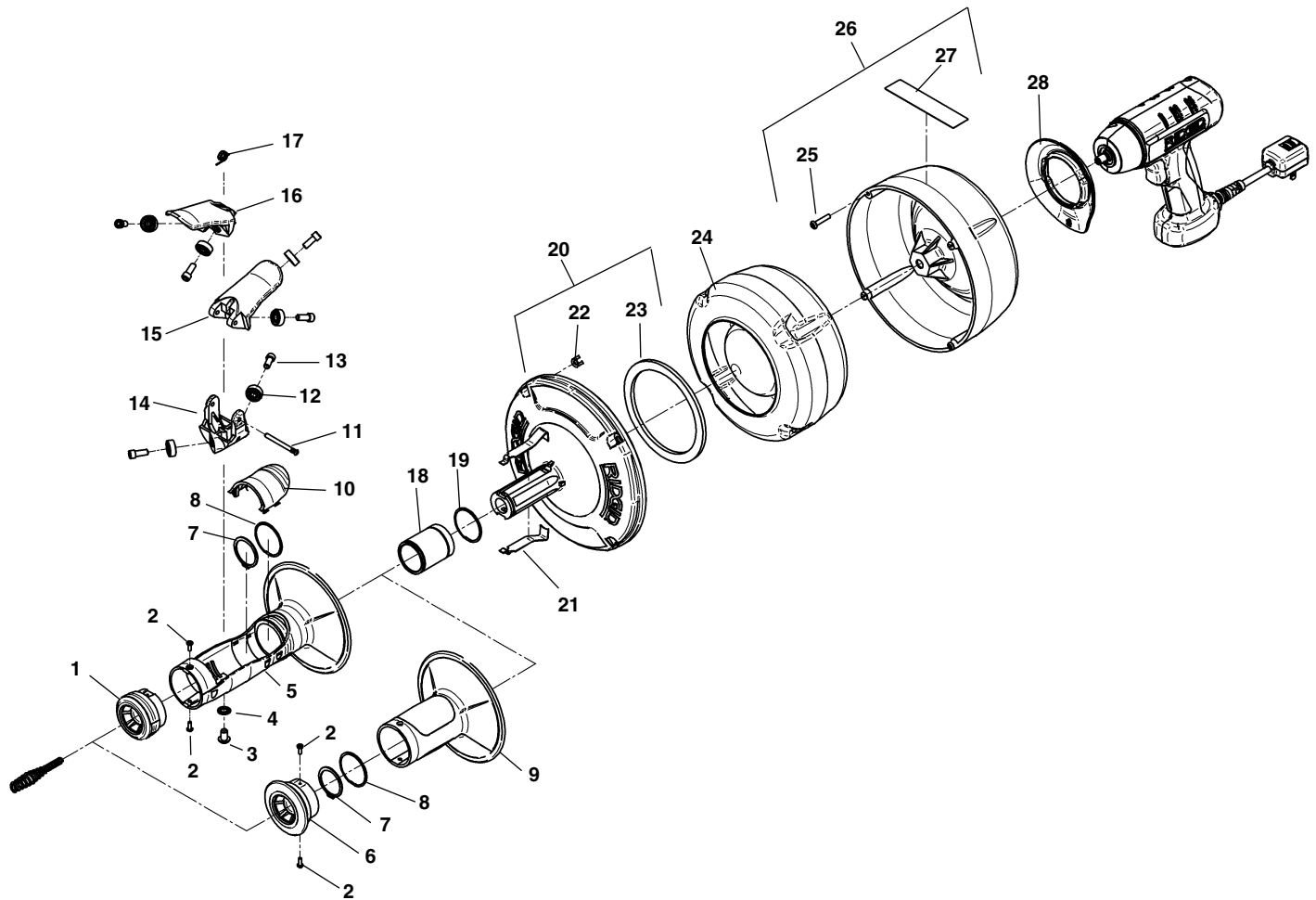

**NOTE: Order parts by Catalog Number only.  
DO NOT order by Reference Number.**

Ref. No.	Catalog No.	Description	Ref. No.	Catalog No.	Description	Ref. No.	Catalog No.	Description
1	24163	Nose Piece, Auto	11	24208	Pivot Pin	21	24243	Clamp Spring
2	24168	Screw	12	67997	Roller Bearing	22	68942	Clips
3	24178	Button Screw 5/16"-18	13	39830	Socket HD Cap Screw	23	47525	Gasket
4	92255	Lock Washer	14	24213	Auto Feed Carriage	24	68917	Drum Liner
5	24183	Hand Grip, Auto	15	24218	Reverse Lever	25	69542	Screw #10-32 X 1"
6	24188	Nose Piece, Manual	16	24223	Forward Lever	26	68932	Drum Back
7	24193	Retaining Ring	17	24228	Torsion Spring	27	24248	Caution Label
8	41512	Spiral Ring	18	24233	Sleeve	28	24253	Trigger Guard
9	24198	Hand Grip, Manual	19	41512	Spiral Ring			
10	24203	Top Grip Cap	20	24238	Drum Front			

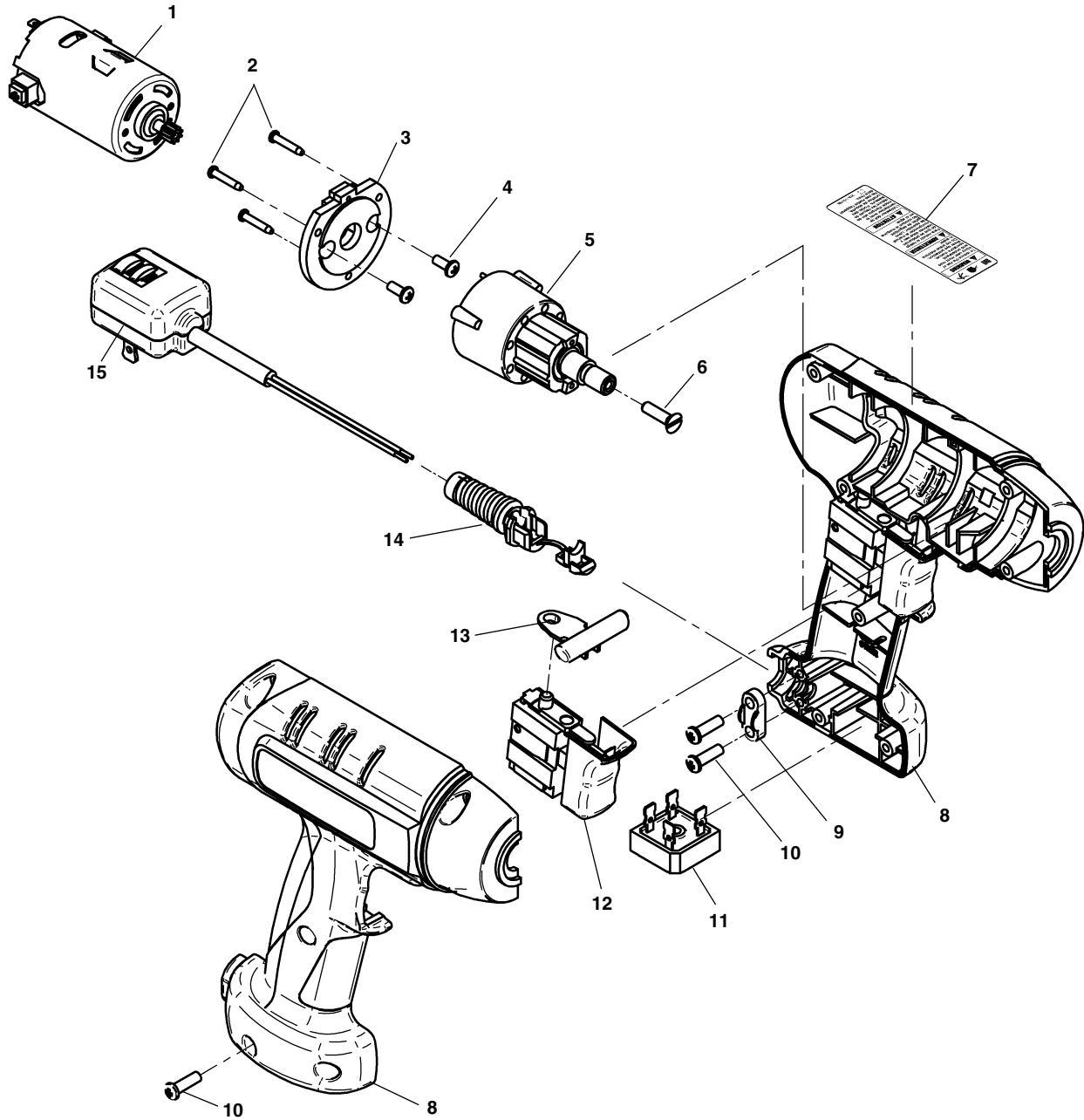

**NOTE: Order parts by Catalog Number only.  
DO NOT order by Reference Number.**

Ref. No.	Catalog No.	Description	Ref. No.	Catalog No.	Description
—	24138	Power Unit 115V	8	24103	Housing Set
—	24143	Power Unit 230V	9	24018	Cord Clamp
1	24078	Motor 115V	10	24113	Screw, #8 x .62
	24148	Motor 230V	11	21758	Rectifier
2	24083	Screws	12	24118	Switch 115V
3	24088	Adapter		24153	Switch 230V
4	17106	Screw, M4 x 10	13	24123	Reversing Lever
5	24093	Gearbox	14	21768	Stain Relief
6	19128	Screw, LH M5	15	24128	Linecord 115V
7	24098	Warning Label		24158	Linecord 230V